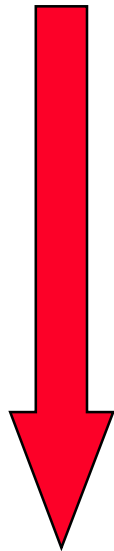
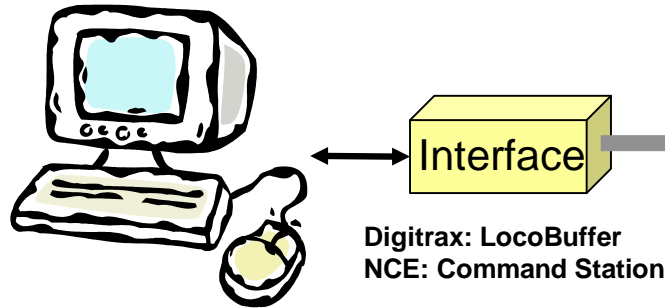

Figure 1, Accessory Decoder System (AD30) Overview



SBS (Optional) System Configuration



AD30 Provides The Following Features:

- 30 NMRA Compliant DCC Accessory (Stationary) Decoders on One Board
- User "Programs" Decoder Addresses with DCC Throttle
- Integrates with SBS or... Standalone (No Computer Necessary)

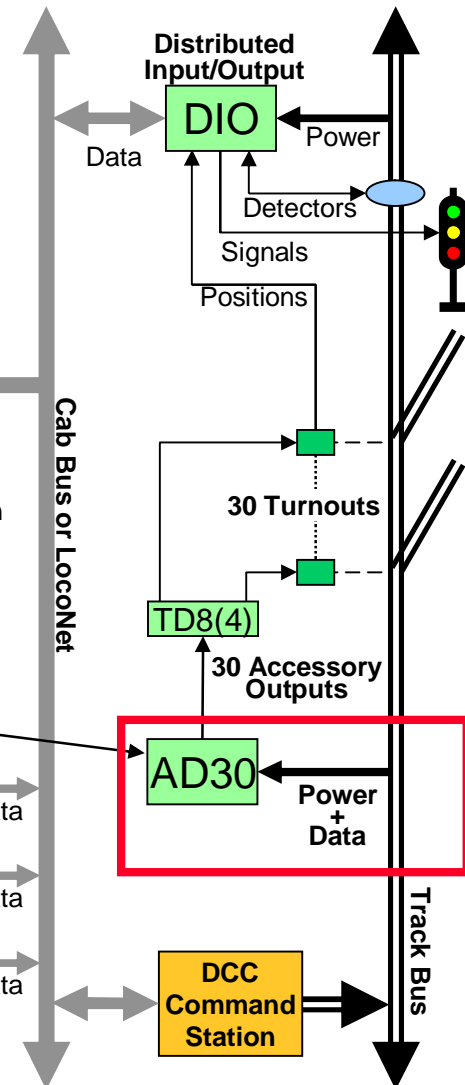

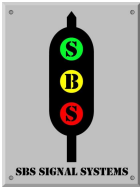

Signals By Spreadsheet (SBS)

Accessory Decoder System (AD30)

Figure 2, Accessory Decoder System (AD30) Board

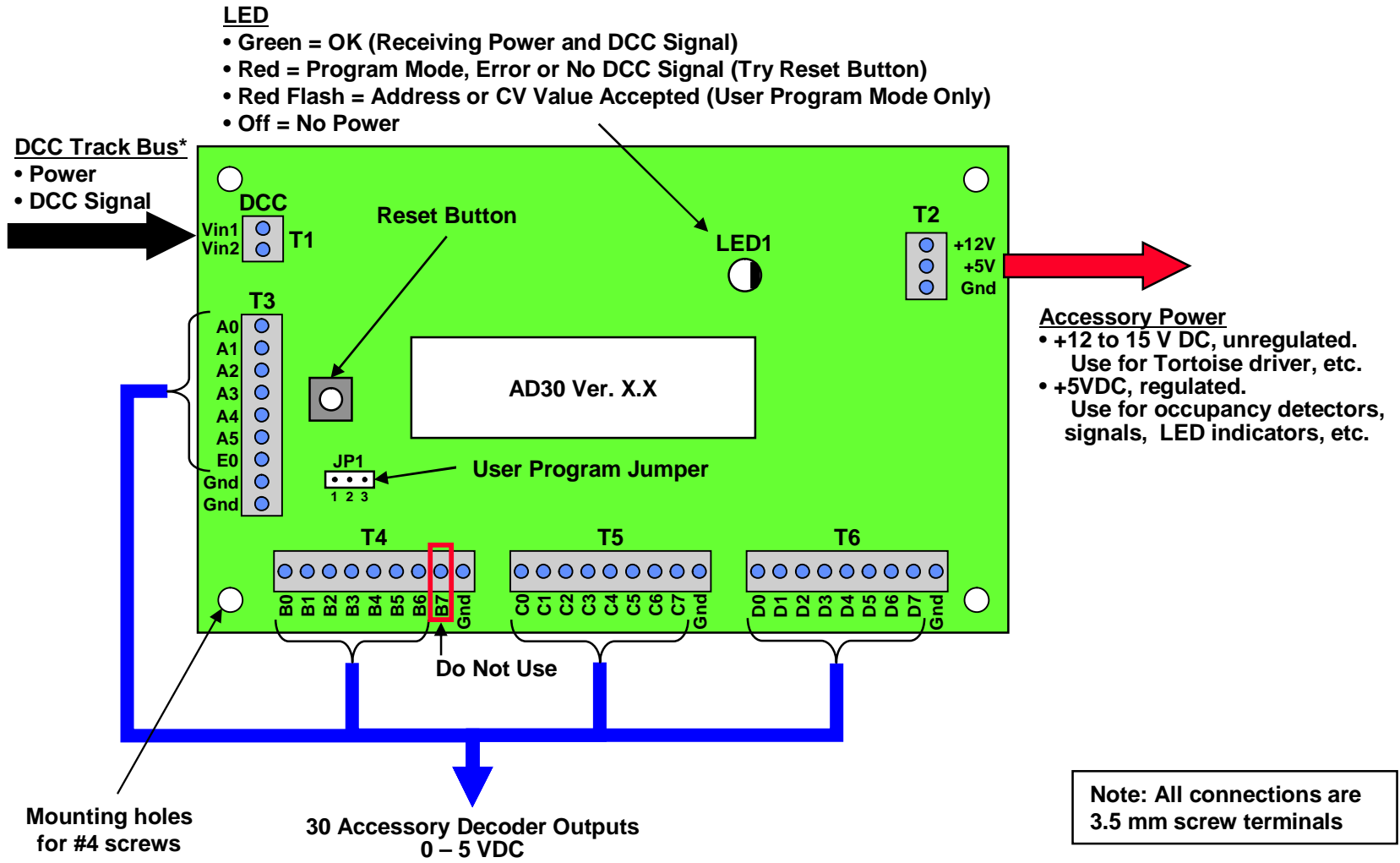

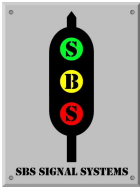

Signals By Spreadsheet (SBS)

Accessory Decoder System (AD30)

Figure 3, Tortoise[®] Driver Board (TD8)

Note: All connections are 3.5 mm screw terminals

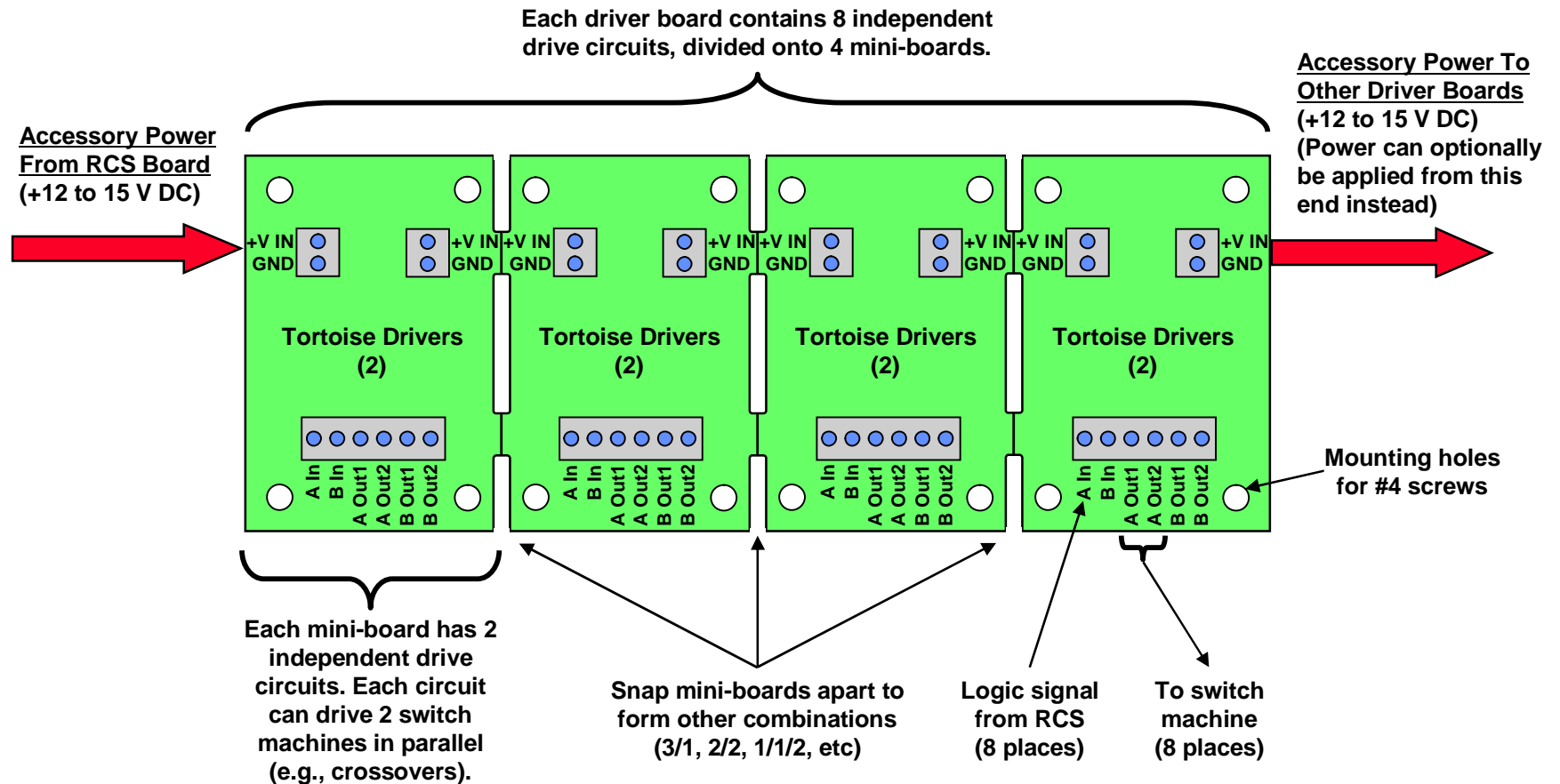

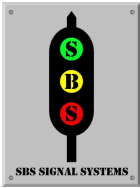

Signals By Spreadsheet (SBS)

Accessory Decoder System (AD30)

Figure 4, Tortoise® Wiring Schematic

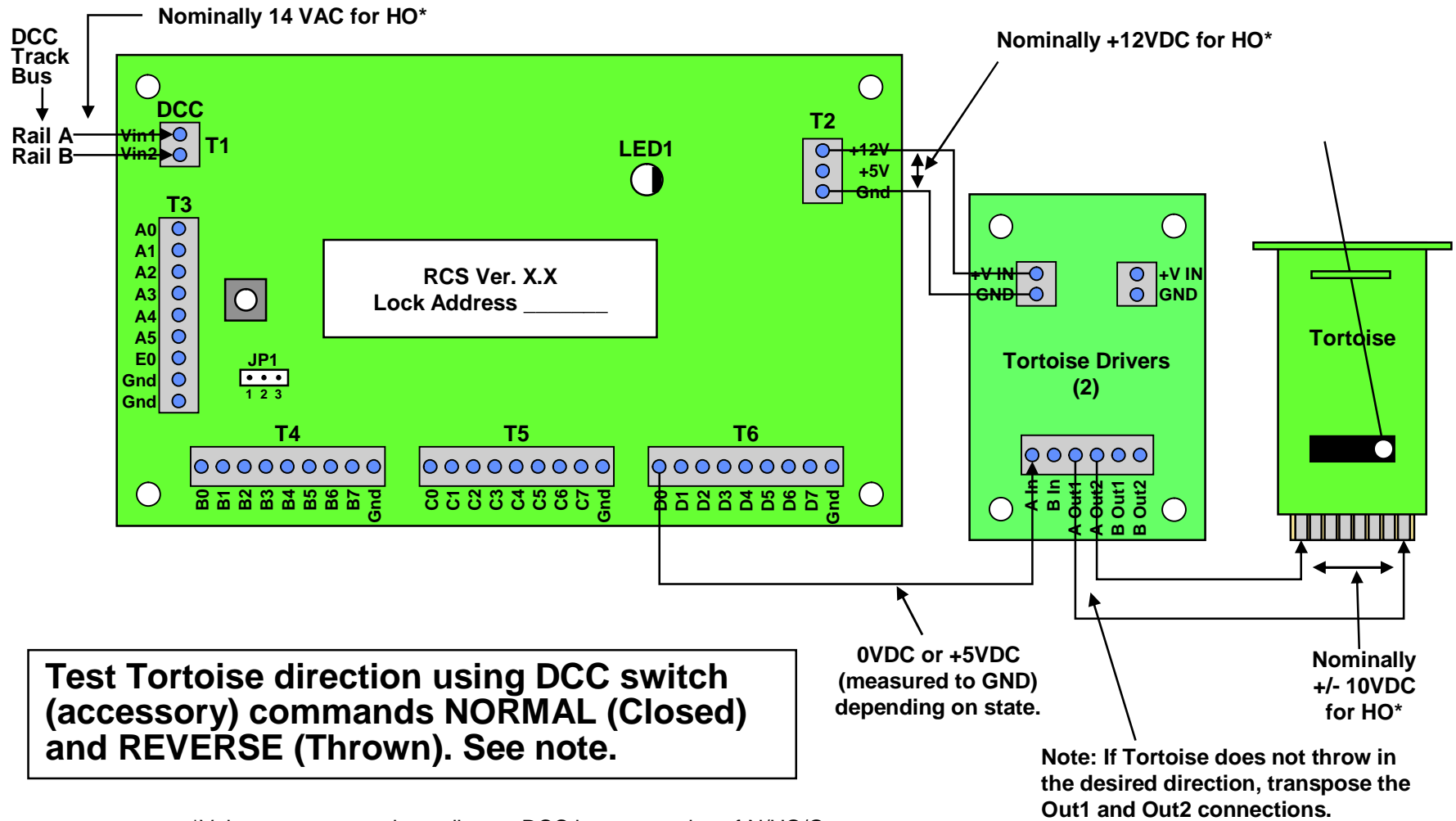

Test Tortoise direction using DCC switch (accessory) commands NORMAL (Closed) and REVERSE (Thrown). See note.

*Voltages may vary depending on DCC booster setting of N/HO/O.

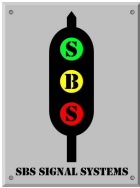

Signals By Spreadsheet (SBS)

Accessory Decoder System (AD30)

Figure 5, AD30 Standard Configuration

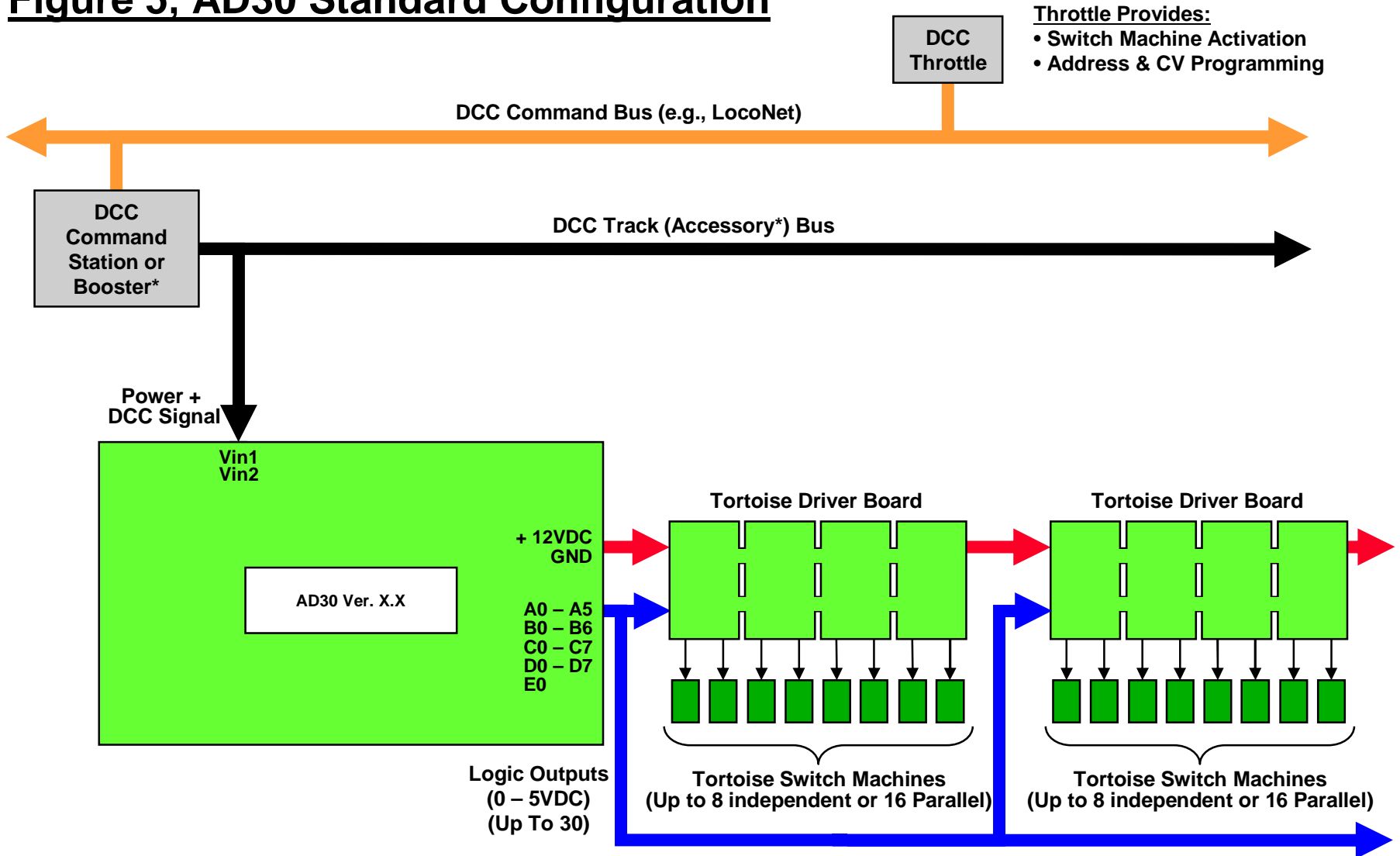

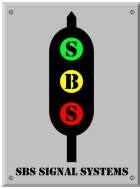

Signals By Spreadsheet (SBS)

Accessory Decoder System (AD30)

Figure 6, LED Switch Position Indicators (Optional)

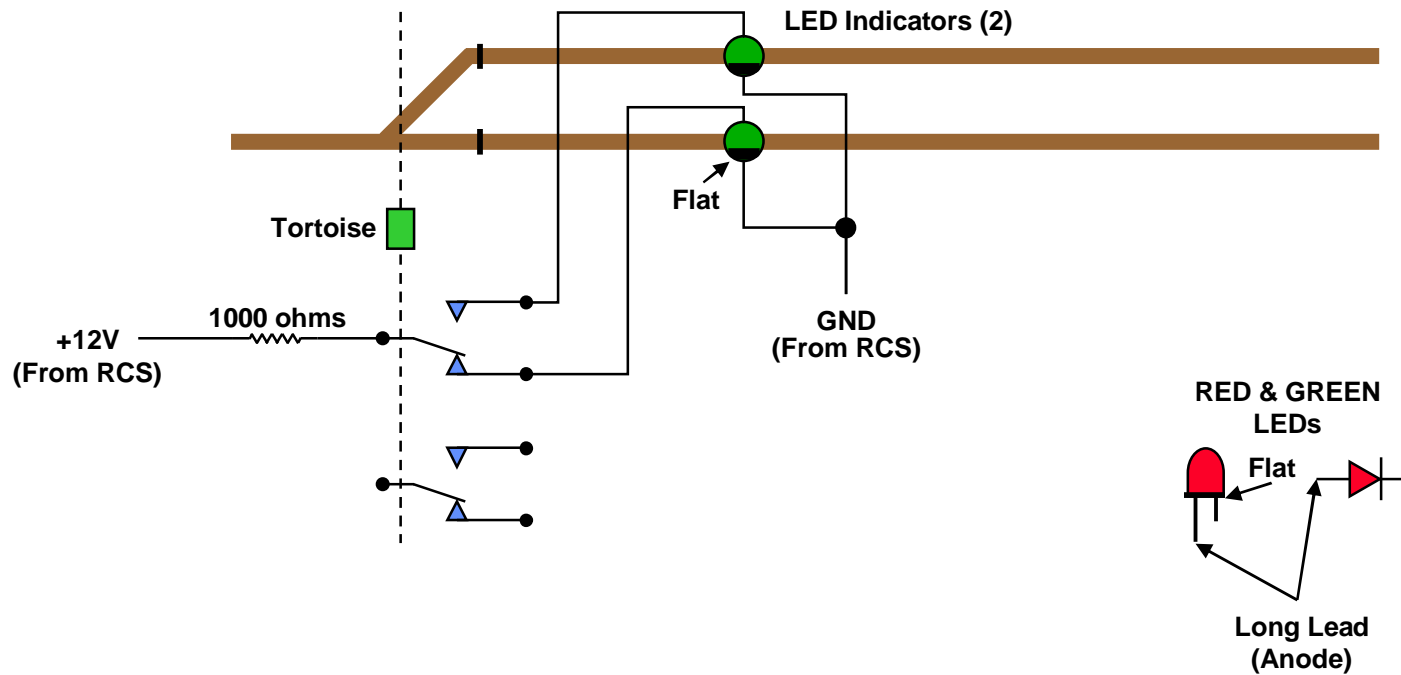

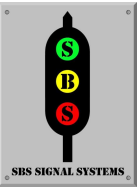

Signals By Spreadsheet (SBS)

Accessory Decoder System (AD30)

Figure 7, Address Log

Accessory Decoder 30 (AD30) Address Log

Note:

Addresses must be programmed in sequence starting with Switch 1.

To restart programming, press RESET.

Valid addresses are 0 to 2047.

*Terminal A4 is not push-pull.

Terminal	Switch	Address
A0	1	
A1	2	
A2	3	
A3	4	
A4*	5	
A5	6	
E0	7	
B0	8	
B1	9	
B2	10	
B3	11	
B4	12	
B5	13	
B6	14	
B7	No Connection	No Address
C0	15	
C1	16	
C2	17	
C3	18	
C4	19	
C5	20	
C6	21	
C7	22	
D0	23	
D1	24	
D2	25	
D3	26	
D4	27	
D5	28	
D6	29	
D7	30	