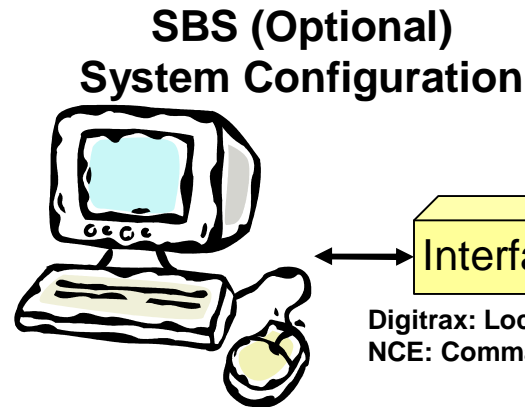
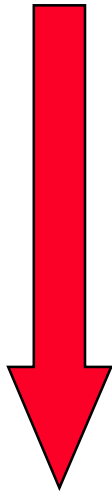
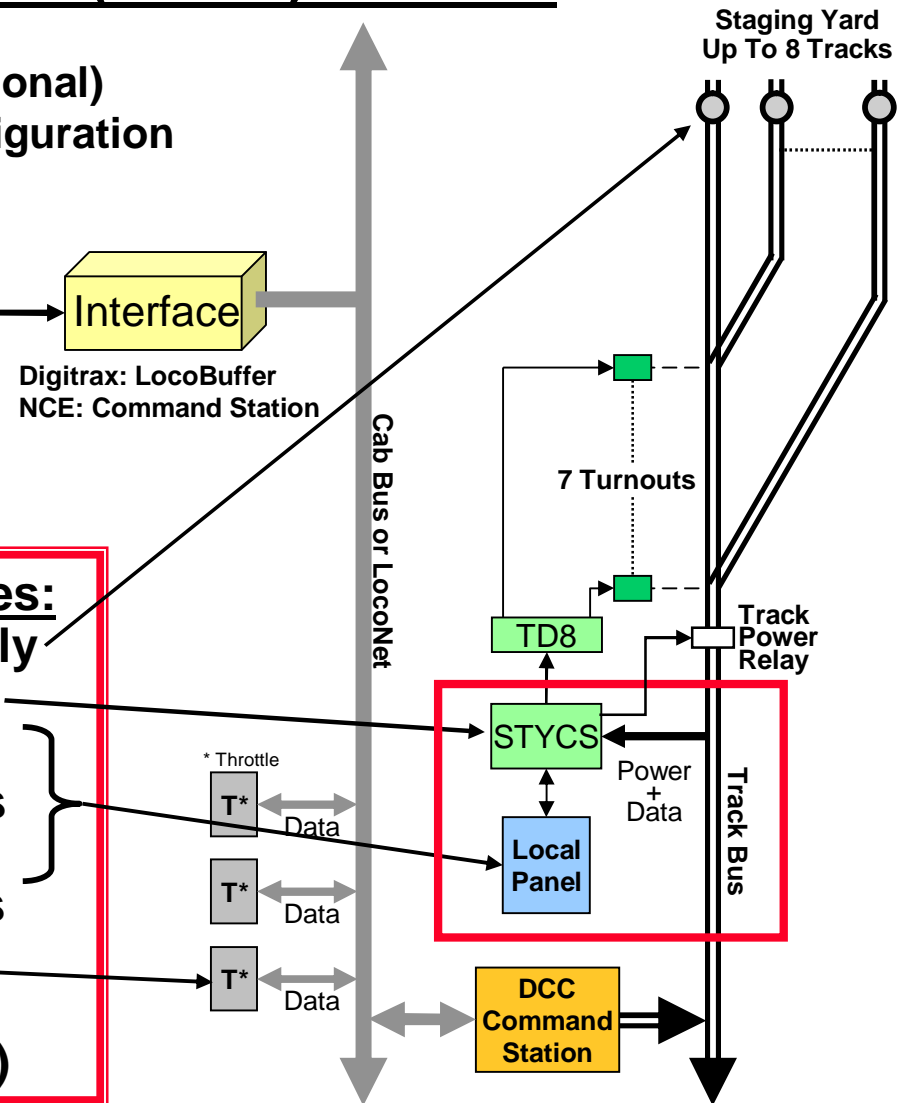

Figure 1, STaging Yard Control System (STYCS) Overview



STYCS Provides The Following Features:

- Photo-sensors stop train automatically
- 7 Accessory Decoders on One Board
- Local Panel Control
- Pushbutton Route Control – 8 Routes
- Local Panel Lockout by Dispatcher
- User “Programs” Decoder Addresses & CV’s with DCC Throttle
- Integrates with SBS or... Standalone (No Computer Necessary)



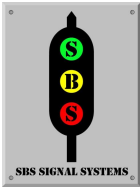

Figure 2, Overview (Continued)

STYCS provides the following features:

- **Designed primarily for stub-ended staging yards**
- **8 routes (8 tracks/pushbuttons, 7 switches) max (at present)**
- **Designed for hidden (not visible to operator) staging:**
 - Photo-sensors determine occupancy of a track
 - Entering train is stopped at the stub end automatically
 - Departing train's track is activated for selectable amount of time
- **All occupied tracks are deactivated when not entering or departing**
 - Turns off locomotive, sound, headlight, etc.
- **LED Status indicators (optional) provide:**
 - Track Occupied
 - Track Selected
 - Track Power ON

} Additional circuitry required (see Figures 9 & 10)
- **Any or all switches may be locked (usually by Dispatcher)**
- **Addresses and CV's programmed with DCC throttle**

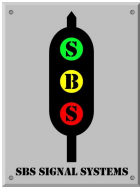
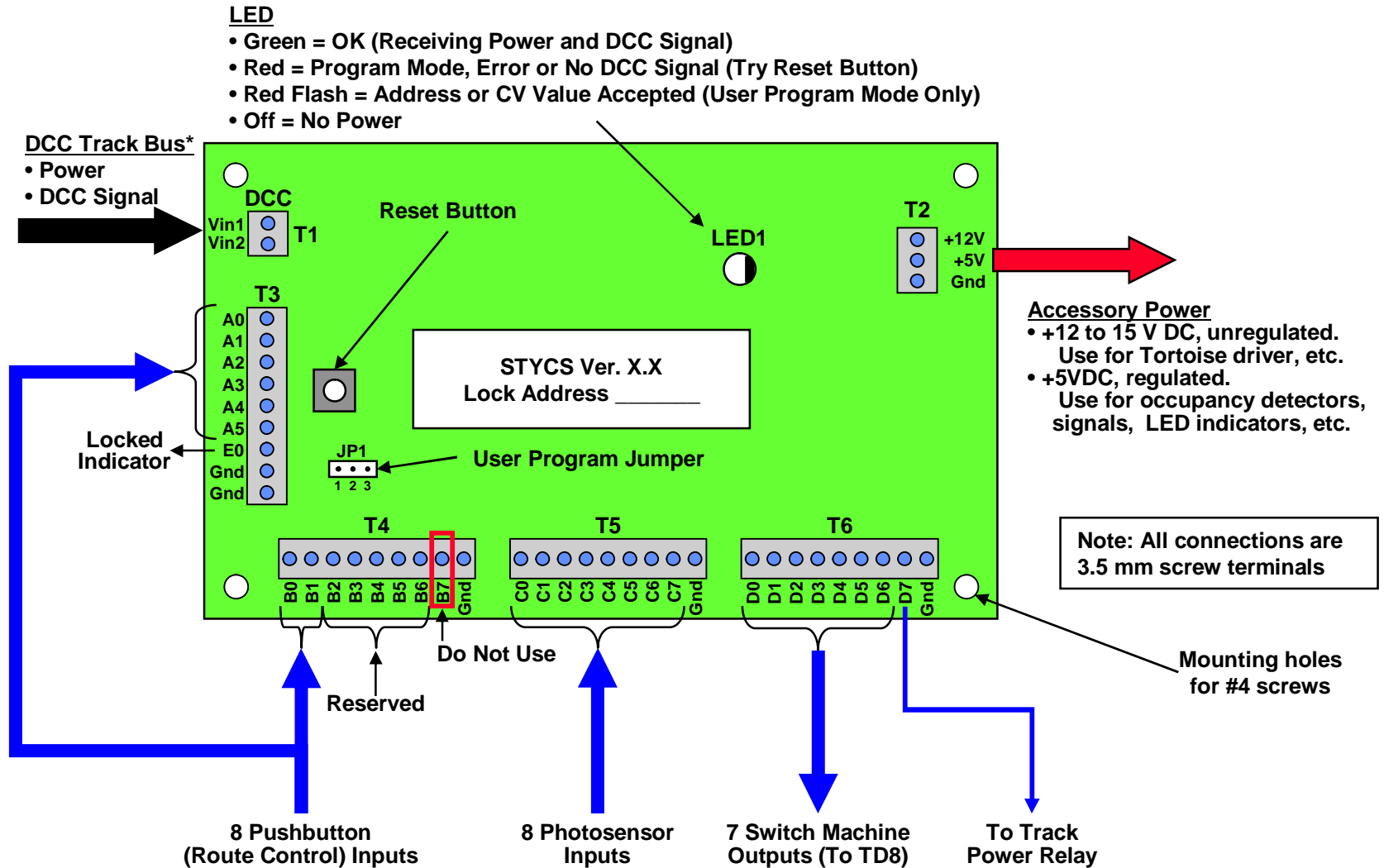

Figure 3, STaging Yard Control System (STYCS) Board



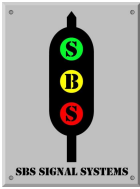
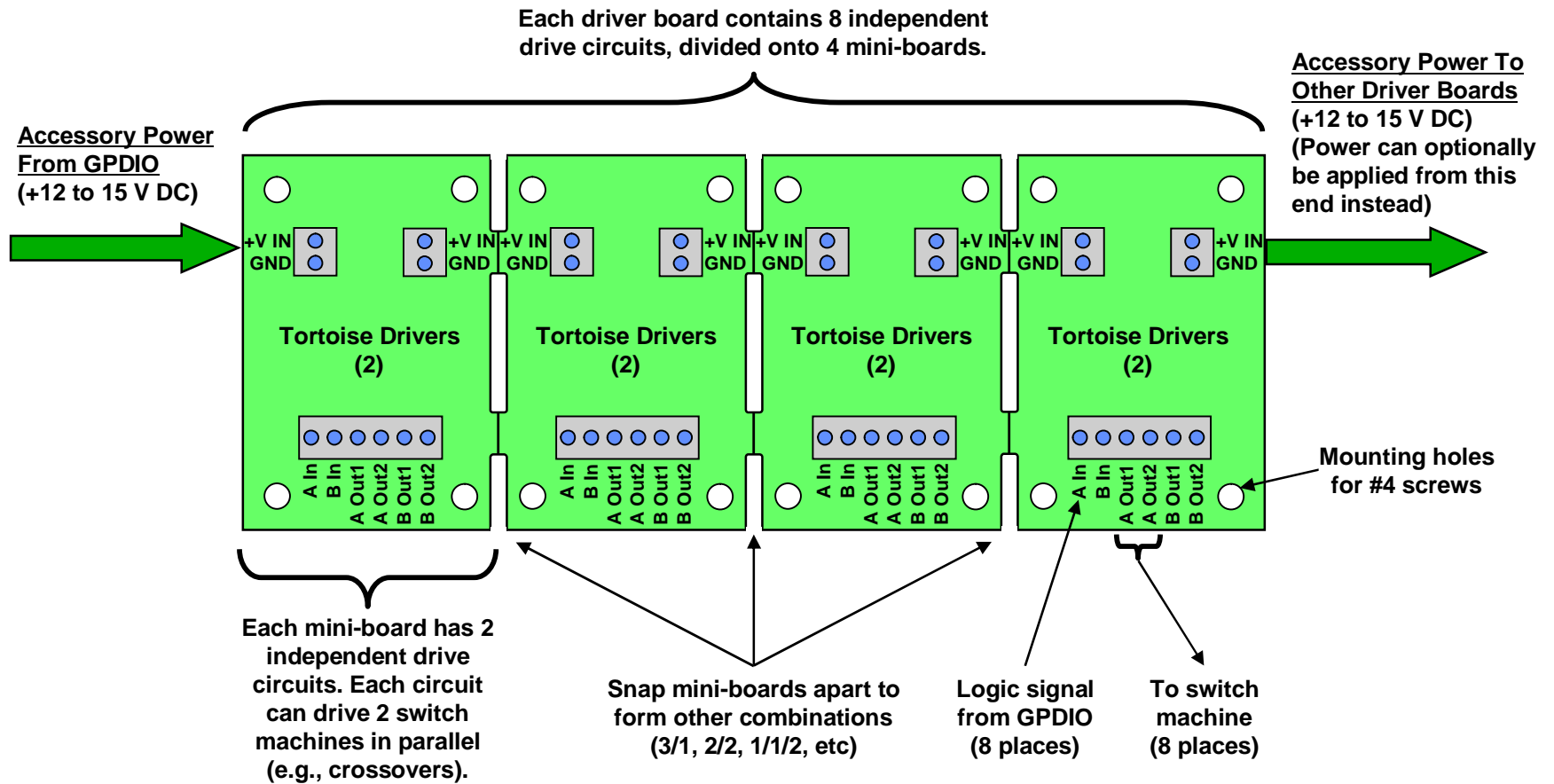
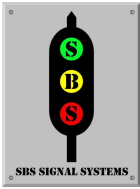

Figure 4, Tortoise[®] Driver Board





Signals By Spreadsheet

STaging Yard Control System (STYCS)

Figure 5, Standard STYCS Configuration

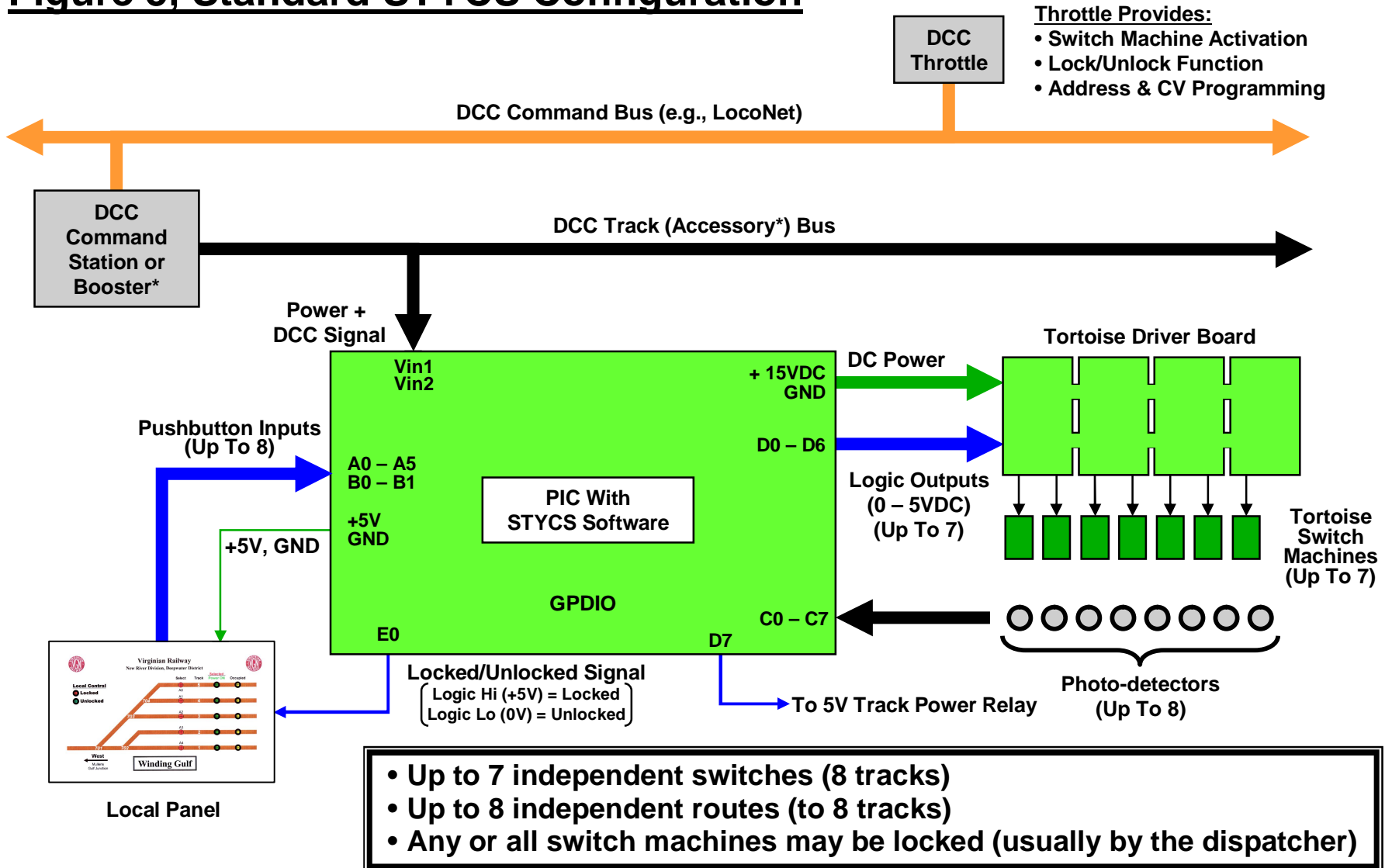

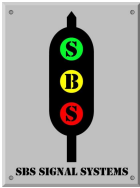

Signals By Spreadsheet

STaging Yard Control System (STYCS)

Figure 6, Control Panel Schematic (Standard Configuration)

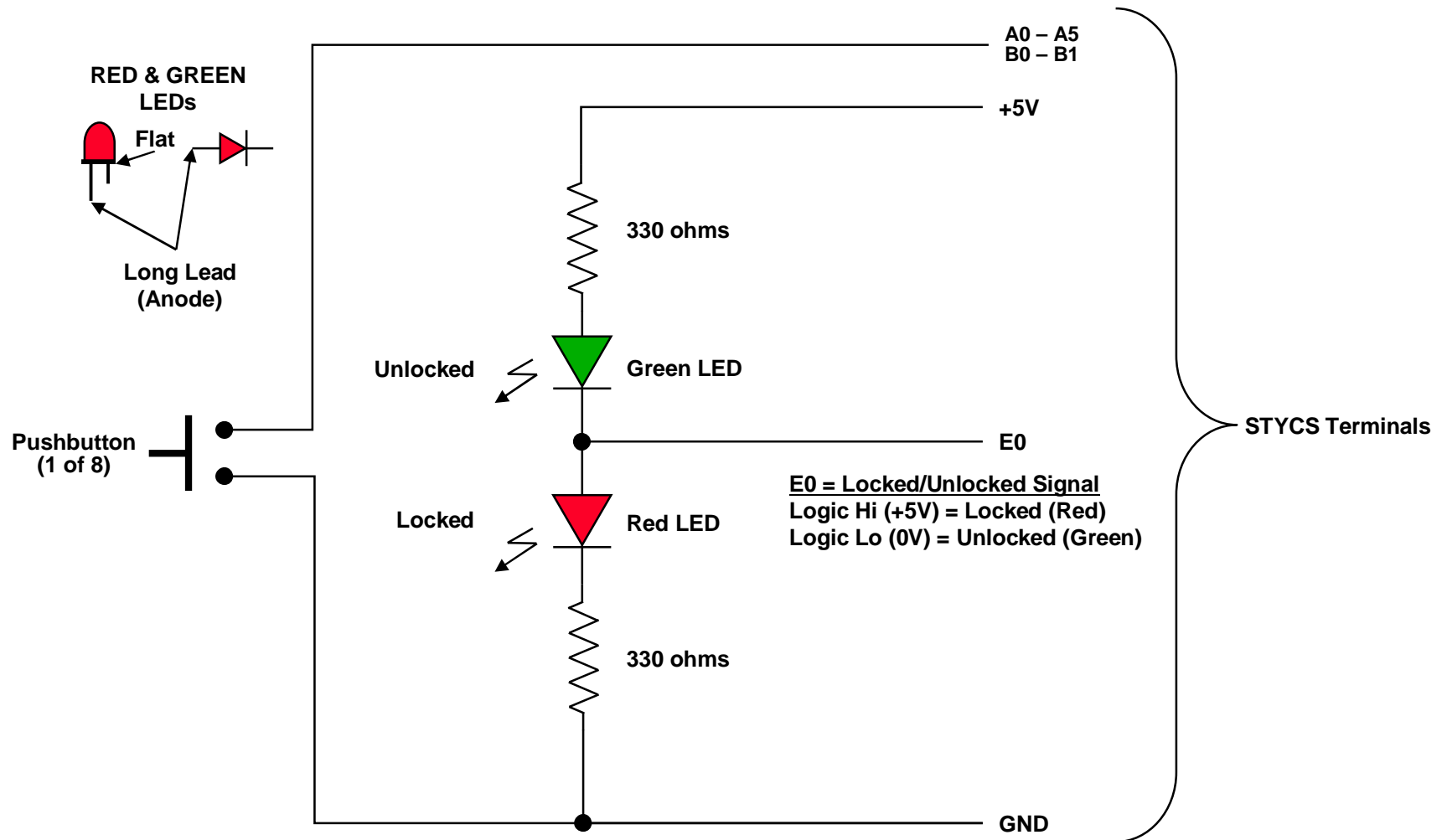

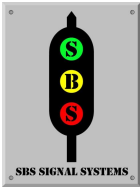
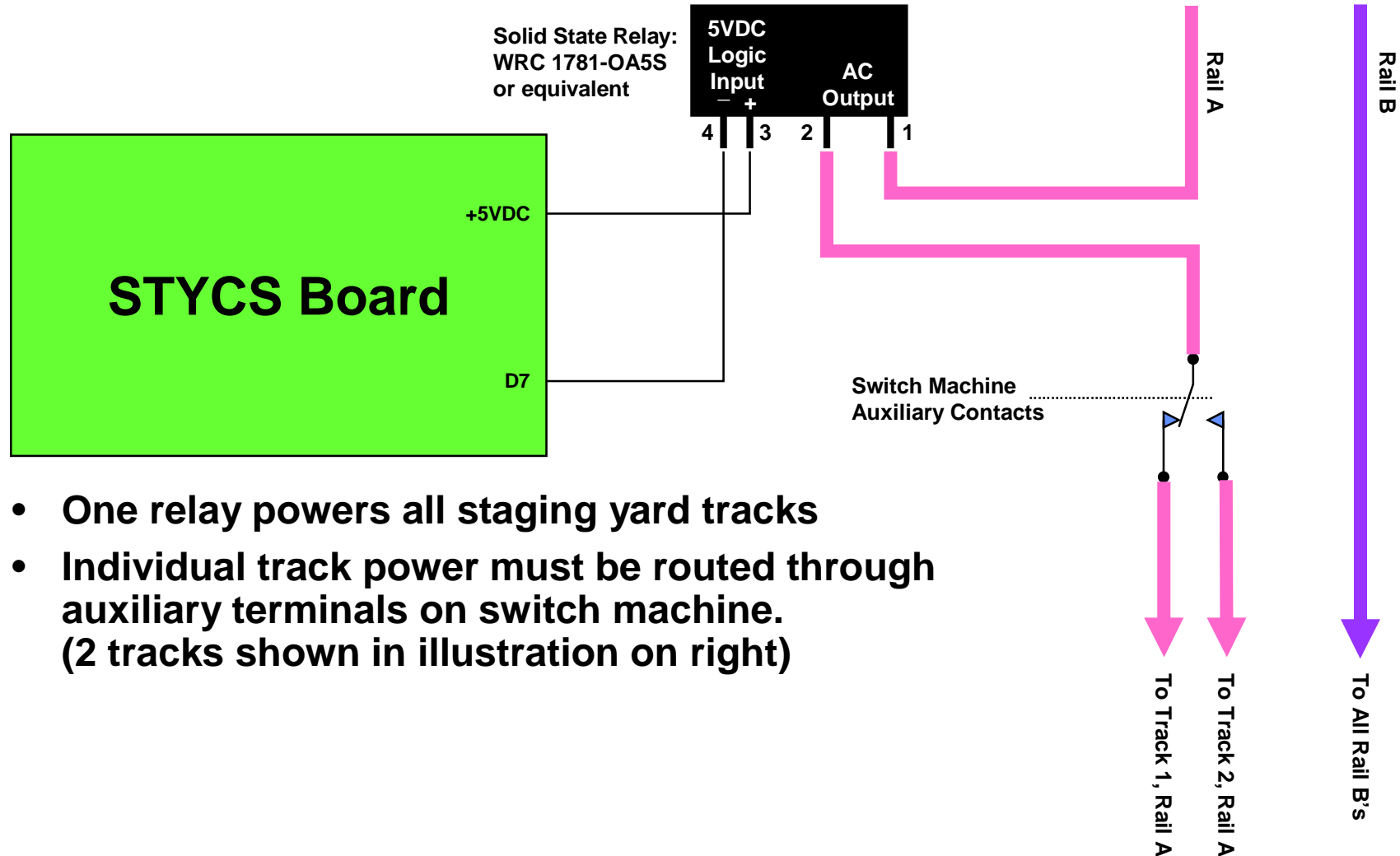

Figure 7, Relay Wiring



- One relay powers all staging yard tracks
- Individual track power must be routed through auxiliary terminals on switch machine. (2 tracks shown in illustration on right)

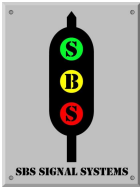
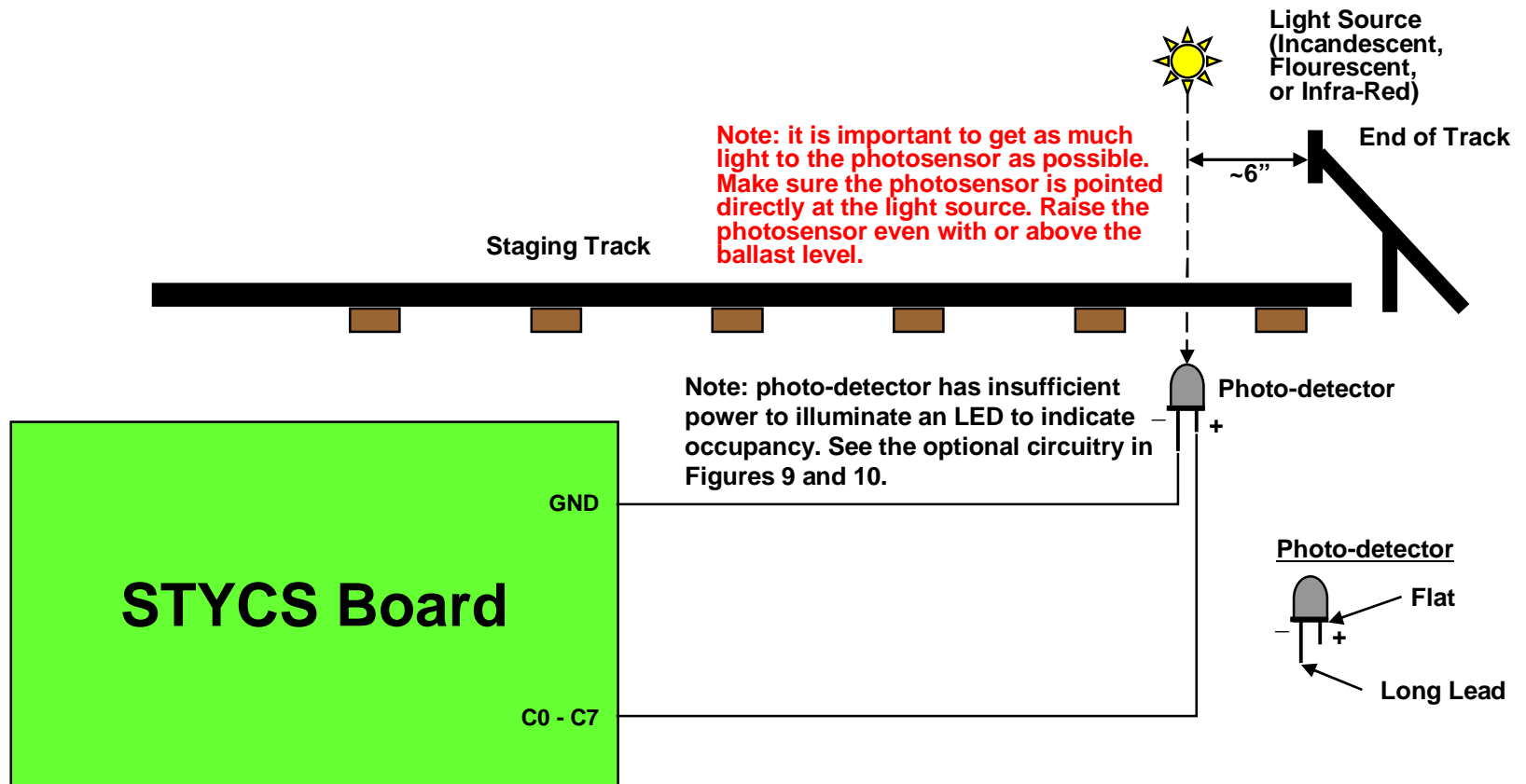

Figure 8, Photo-sensor Wiring (Standard Configuration)



- **Photo-detector Determines Occupancy**
 - Light path broken: track occupied
 - Light path unbroken: track clear
- **C0 corresponds to track selected by A0 pushbutton; C1 to A1; etc.**

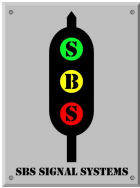
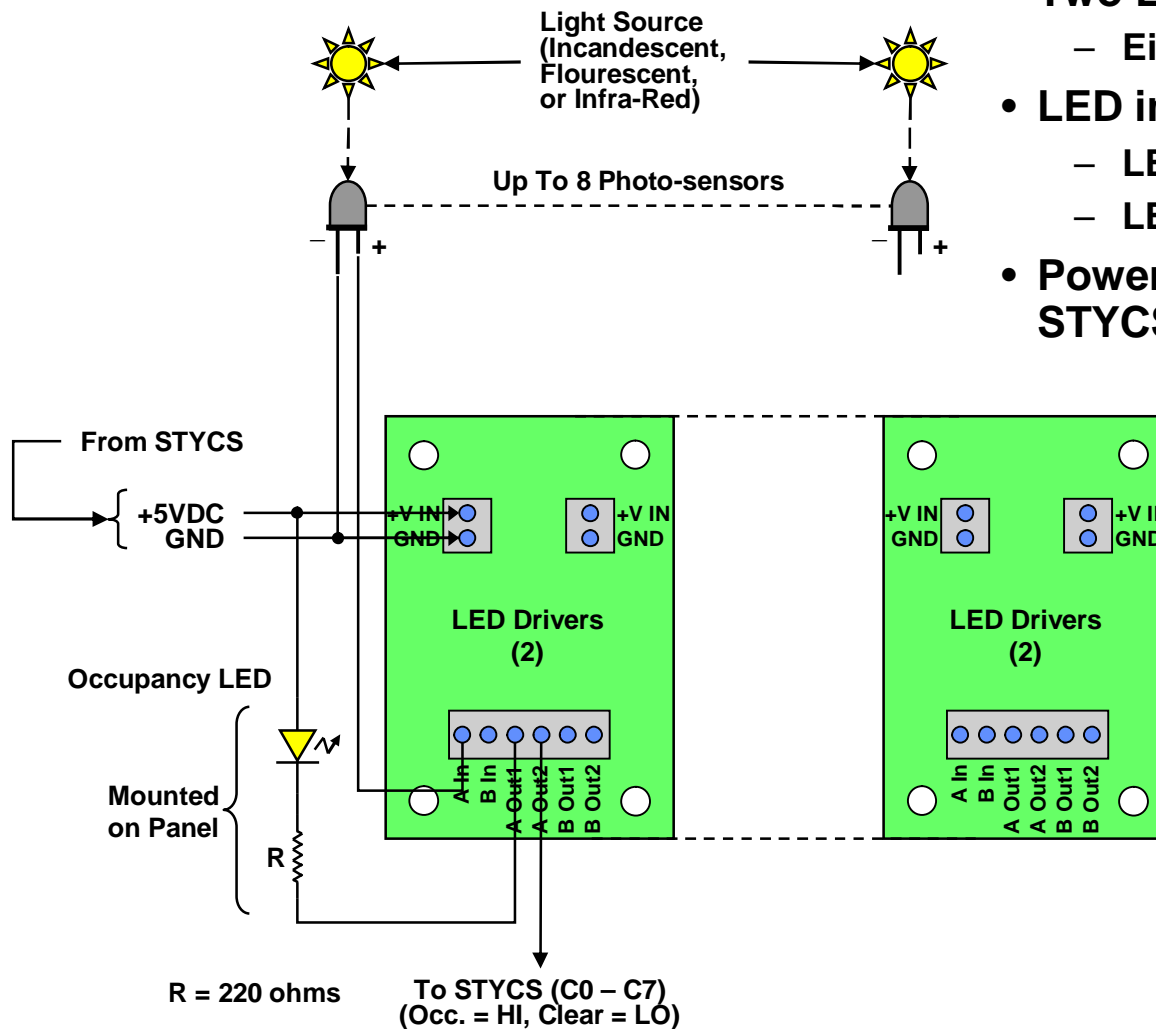
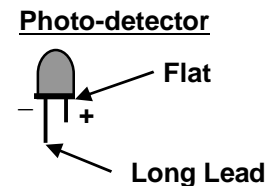
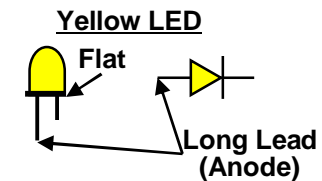
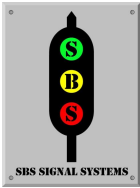

Figure 9, "Track Occupied" (Optional Indicator)



- Two LED Drivers per mini-board
 - Eight LED Drivers per board
- LED indicates occupancy
 - LED lit: track occupied
 - LED unlit: track clear
- Power for all devices provided by STYCS board





Signals By Spreadsheet

STaging Yard Control System (STYCS)

Figure 10, "Selected/Power ON" (Optional Indicator)

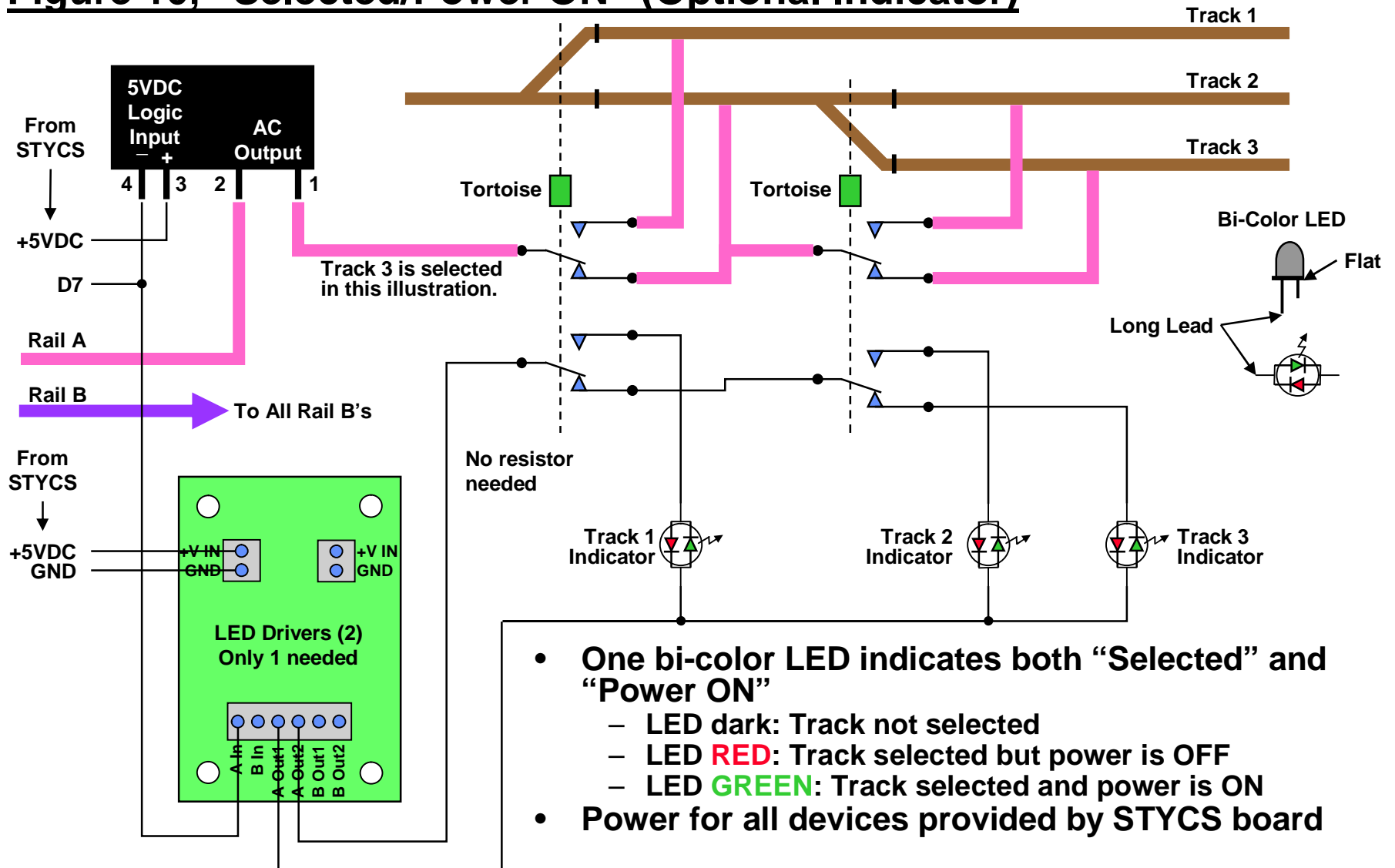

- One bi-color LED indicates both "Selected" and "Power ON"
 - LED dark: Track not selected
 - LED **RED**: Track selected but power is OFF
 - LED **GREEN**: Track selected and power is ON
- Power for all devices provided by STYCS board

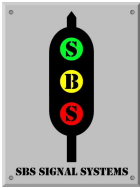

Signals By Spreadsheet

STaging Yard Control System (STYCS)

Figure 11, Worksheet Example (6 Tracks)

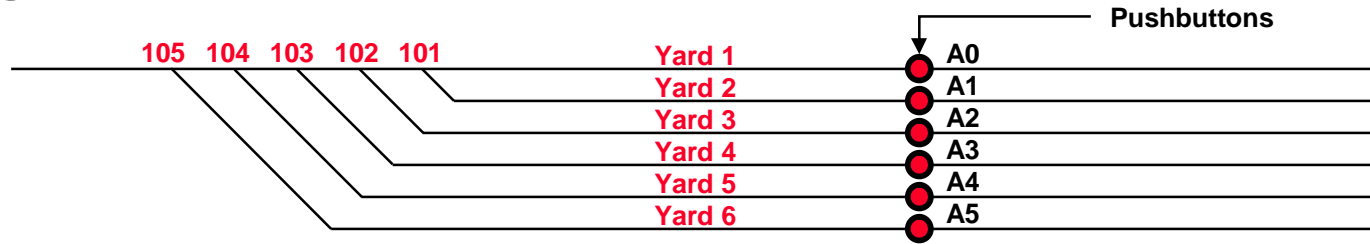

Example with 6 routes, 5 switches. Lock address = 100

Switch #	Wire Color	Inputs	Track CV#	CV (N'S) Value	Switch Position (N/C or R/T)										Don't Move CV Value (X's)	Don't Move CV#
					Relay Output (6)	SW7 (7)	SW6	SW5	SW4	SW3	SW2	SW1	SW0	SW-1		
Yard 1	White	A0	81	31					N	N	N	N	N	N	0	98
Yard 2	Pink	A1	82	30					N	N	N	N	R	0	99	
Yard 3	Brown	A2	83	28					N	N	N	R	X	1	100	
Yard 4	Grey	A3	84	24					N	N	R	X	X	3	101	
Yard 5	Chartruse	A4	85	16					N	R	X	X	X	7	102	
Yard 6	Orange	A5	86	0					R	X	X	X	X	15	103	
B0		B0	87	0										0	104	
B1		B1	88	0										0	105	
Lock (L/U)	Beige	E0 out	97	0					U	U	U	U	U			
Relay Activation (Seconds)														90	106	
Relay Activation Table (Y/N)									Y	Y	Y	Y	Y	31	107	
	Red/Black	+5/GND			Note: N=Normal, R=Reverse, X=Don't Move, L=Locked, U=Unlocked, Y=Yes, No=No											

Note: User worksheet entries are in RED.

Legend:
 N = Normal
 R = Reverse
 X = Don't Move
 L = Locked
 U = Unlocked
 Y = Yes
 No = No

Instructions:

1. Enter on Worksheet header the Staging Yard Name and Lock Address. (Staging Yard Name is an optional entry.) Lock Address and Switch # address range is 0-2047.
2. Enter on Worksheet the Switch #'s, Track Names, and Wire Colors. Leave unused switches and tracks blank. (Track Names and Wire Colors are optional entries.)
3. Enter on Worksheet the required Switch Position (N, R, or X) for each Track. (Ask yourself: when A0 is pressed, what position should SW1 go to? SW2? SW3? Etc.)
4. Enter on Worksheet an "L" in the Lock row for each switch you want the dispatcher to be able to lock (that is, disable local control). Enter a "U" otherwise. (See Note 2)
5. Enter on Worksheet the amount of time you want the relay activated after a button push in the Relay Activation (Seconds) cell.
6. Enter on Worksheet a "Y" in the Relay Activation Table for each input (A0 to B1) that you want to have actuate the relay. Enter a "No" otherwise.
7. Calculate the CV values by adding the CV Weight (1,2,4,8,etc.) for each entry of N's and L's in the left CV Value column, for X's and Y's in the right CV Value column.
8. Place the Jumper on the STYCS board in "Program" position. (Jumper 1-2)
9. Program the Lock and Switch #'s using your throttle in "Switch Mode" in the following order: Lock, SW1, SW2, ... (Select address, press either N or R to program)
10. Program the CV#'s and their corresponding CV Values with your throttle in "Ops Mode". Use a non-existent locomotive address number - but not zero.
11. Replace the Jumper on the STYCS board to "Default" position. (Jumper 2-3)

Note:

1. The Lock Address and Switch #'s should be unique on the layout. Exceptions may exist when multiple activations for the same address are desired.
2. The Lock Address and Switch #'s must always be entered in order (Lock, SW1, SW2, etc.). CV Values may be entered in any order.
3. Outputs D0 to D6 are switch outputs (N=Hi=1, R=Lo=0); E0 Out is a lock indicator output (Locked=Hi=1, Unlocked=Lo=0)
4. Inputs A0 to B1 are pushbutton inputs and must be pulled low for local operation. Lock Address locks switches indicated by "L" in CV97 (N-->Locks, R-->Unlocks)
5. For some DCC systems: N(Normal)=C(Closed), R(Reverse)=T(Thrown), "Switch Mode"="Select Acc", "Ops Mode"="Program On The Main"
6. *Power LED will flash from GREEN to RED then back to GREEN when a program operation is accepted.

A blank STYCS Worksheet can be downloaded from the SBS website:
www.SignalsBySpreadsheet.com